



Black Diamond™ Diamond Scoring System

Complete Diamond Scoring System

Polycrystalline Diamond Scoring Tip

Carbide Wear Surfaces

Traditional Carbide Axle

Traditional Hardened Steel Insert

Pre-Loaded for Easy Implementation



MacInnes Tool Corporation

1700 Hudson Avenue
Rochester, NY 14617 USA

t 585.467.1920

f 585.467.7807

www.macto.com

D

Black Diamond™ Diamond Scoring Wheels

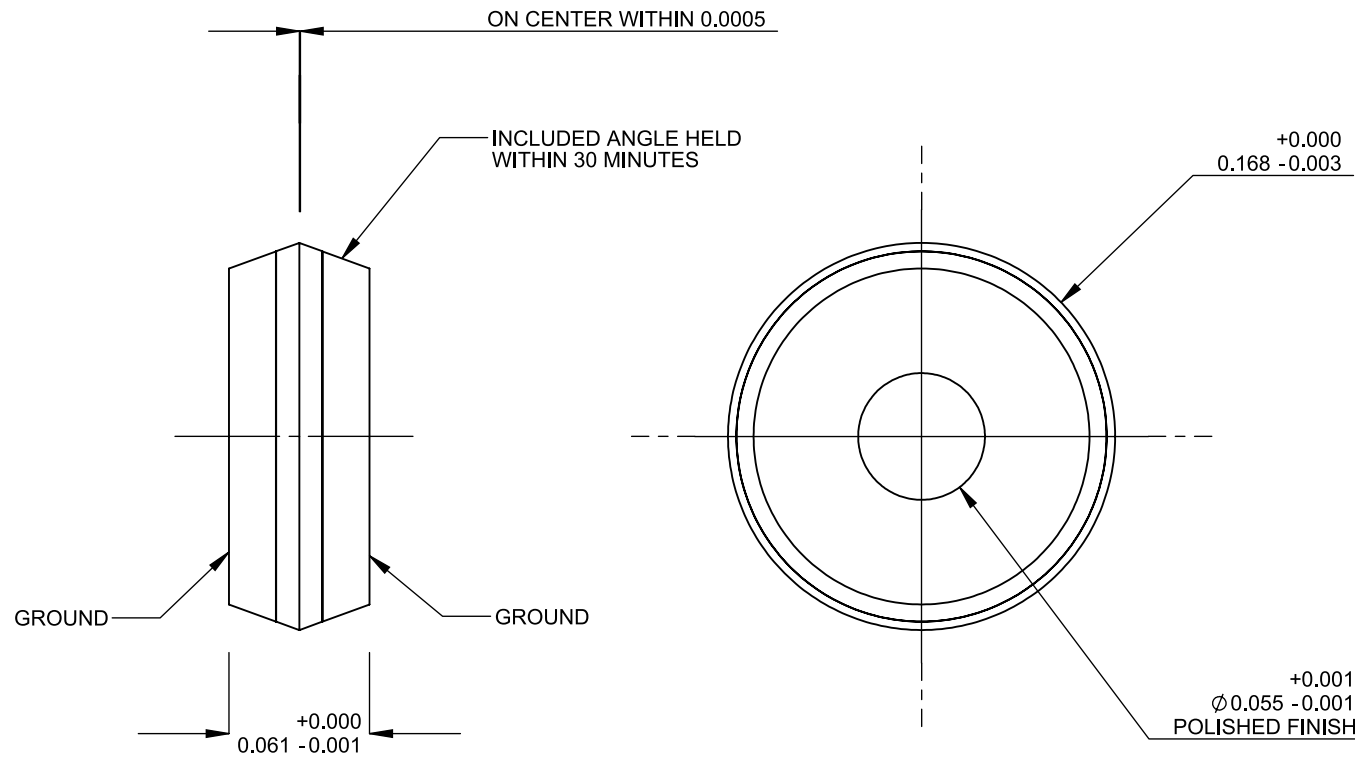
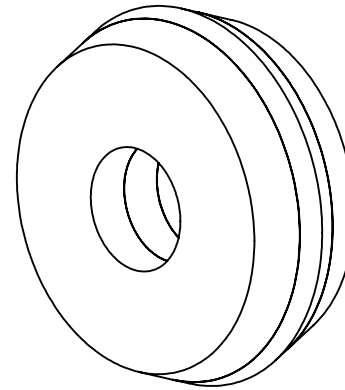

Part Number:	D
Material:	Polycrystalline Diamond and Carbide
Finish:	Ground
Drawn by:	BZDesign
Dimensions:	Inches
Scale:	12:1
Date:	08.25.2008
Outside Diameter:	0.165 - 0.168
Inside Diameter:	0.055 - 0.057
Wheel Caliper:	0.060 - 0.061
Wheel Angle:	Stock Angles ± 0.5 Degrees
Cutting Edge:	0.0005 of Center of Wheel



**MacInnes Tool
Corporation**

1700 Hudson Avenue
Rochester, NY 14617 USA
t 585.467.1920
f 585.467.7807

www.macto.com